

# CLINCHING FASTENERS CO., LTD.

## K NUTS 六角壓鉚螺母(Type B)

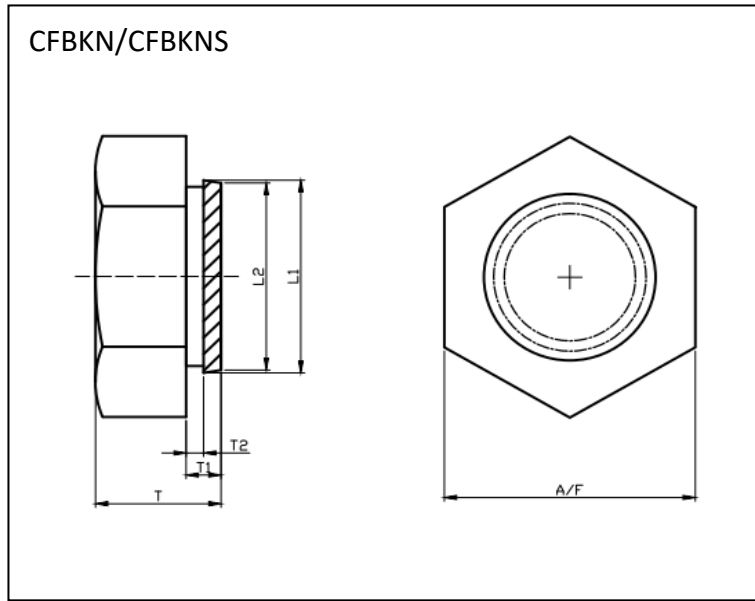

**Material 材質 : Steel 鋼 (CFBKN) / Stainless Steel 不鏽鋼 (CFBKNS)**

**Finish 表面: Cr3+ Zinc 三價鋅 (CFBKN) / Plain 原色 (CFBKNS)**

CFBKN / CFBKNS

Dimensions: ISO metric/mm

Part Code 產品編號	Thread Size 螺紋尺寸	Sheet Thickness 板厚	A/F ±0.1	T ±0.13	T1 +0 -0.13	T2	L1 ±0.13	L2 +0.05 -0.13	Hole in Sheet “d” 板孔徑
CFBKN-M25 CFBKNS-M25	M2.5x0.45	1.5	5.5	3	1.4	0.9	4.7	4.5	4.5
CFBKN-M3 CFBKNS-M3	M3x0.5	1.5	5.5	3	1.4	0.9	4.7	4.5	4.5
CFBKN-M4 CFBKNS-M4	M4x0.7	1.5	7	3.2	1.4	0.9	5.7	5.5	5.5
CFBKN-M5 CFBKNS-M5	M5x0.8	1.5	8	4	1.4	0.9	6.75	6.5	6.5
CFBKN-M6 CFBKNS-M6	M6x1.0	1.5	10	5	1.4	0.9	8.3	8	8